

# SILT FENCE ALTERNATIVE "A" (SP-2A)

(MATERIAL: SILT SHIELD OR APPROVED EQUIVALENT)

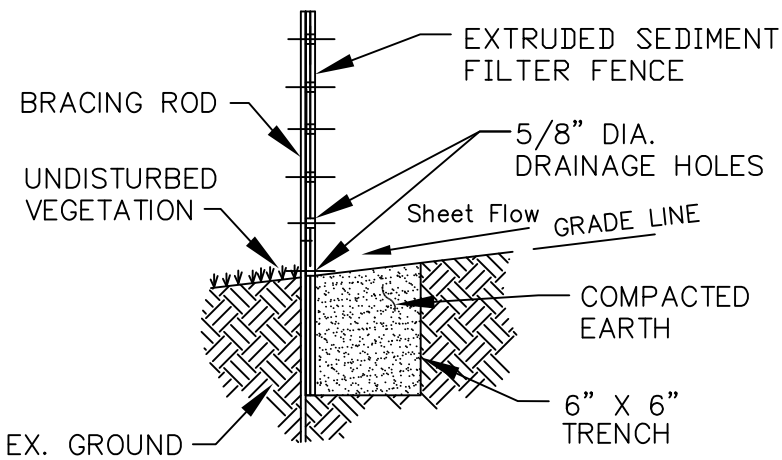

**SECTION B-B**

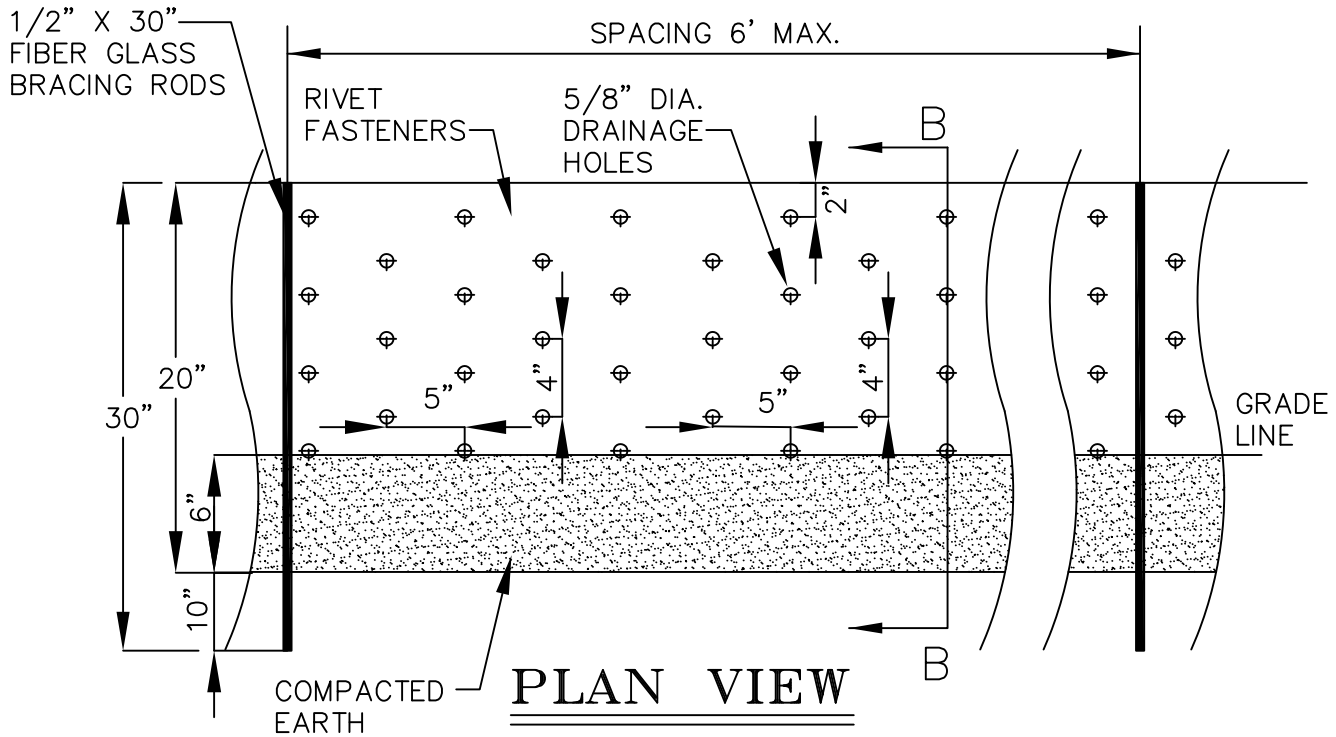
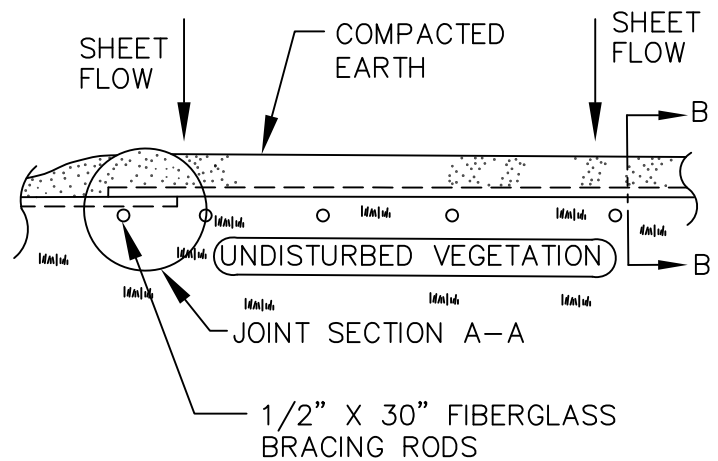

## 2% GRADE MAXIMUM SLOPE

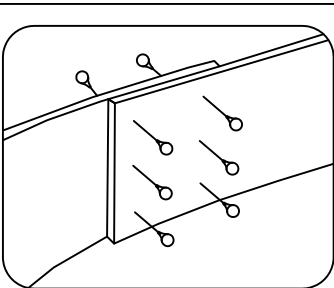

### Splicing Procedure:

Splicing EXTRUDED SEDIMENT FILTER FENCE is achieved beginning with an overlap of a min. of 8" of the EXTRUDED SEDIMENT FILTER FENCE ends secured with six of our plastic ratchet rivet push-in fasteners. Locate three, evenly spaced, vertically, at least 2" from each edge of the splice.

### Optional Heat Splicing:

Overlap a minimum of eight inches. Melt a thin layer of EXTRUDED SEDIMENT FILTER FENCE with torch from top to bottom. Immediately press both layers together for a minimum of 5 second. Check for total lamination from top to bottom of material. (Do not apply heat to filter)